

APEX - IV

Automatic Hydraulic Four Head Aluminum Corner Crimping Machine

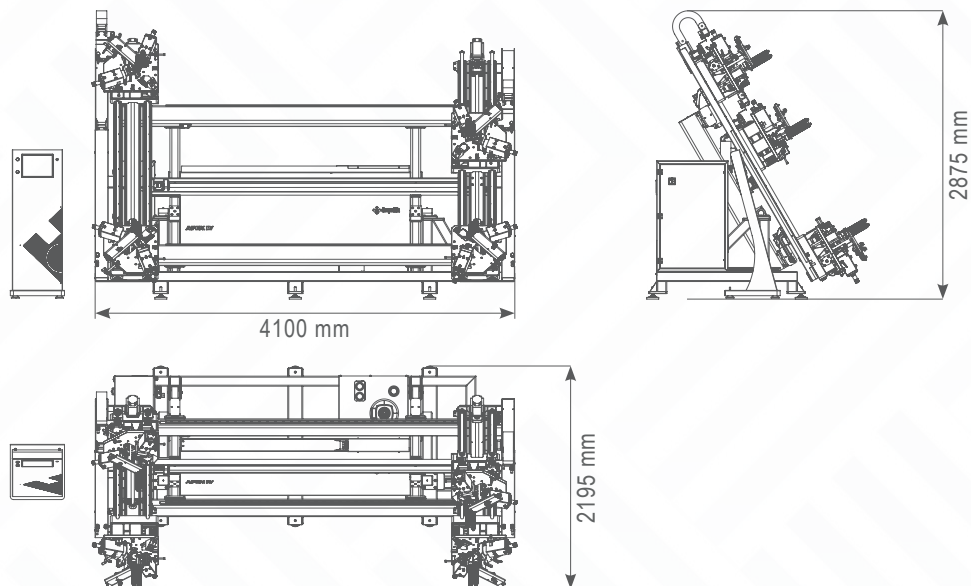

APEX- IV features simultaneous assembling of all 4 corners of the profile by combining the precision of servo positioning and power of hydraulic system to offer quick solutions to users. APEX- IV enables a seamless corner assembling process by minimizing user errors thanks to the two-stage hydraulic pressure system.



APEX - IV

Automatic Hydraulic Four Head Aluminum Corner Crimping Machine



PROFILE SIZES

Minimum profile length	515 mm (vertical) - 515 mm (horizontal)
Maksimum profile length	2000 mm (vertical) – 3400 mm (horizontal)

CRIMPING BLADES

Travel distance	40 mm
Distance between blades	100 mm
5 mm crimping blade set	8 pcs
7 mm crimping blade set	8 pcs

POSITIONING SPEED

X Axis (Longitudinal)	15 m/min
Y Axis (Lateral)	15 m/min

ELECTRICAL

Maximum power	8.4 kW
Voltage	400V 3N PE AC
Frequency	50-60 Hz

AIR

Pressure	6-8 Bar
Air consumption	60,8 L/min

OPERATIONAL AREA

Safe working area with safety barrier	•
12" Touchscreen	•
Crimping set for custom profiles	○
Barcode reader	•

• Standard ○ Opsiyonal