

# ORBIT - V

Automatic PVC Corner and Surface Cleaning Machine (4 Surfaces)

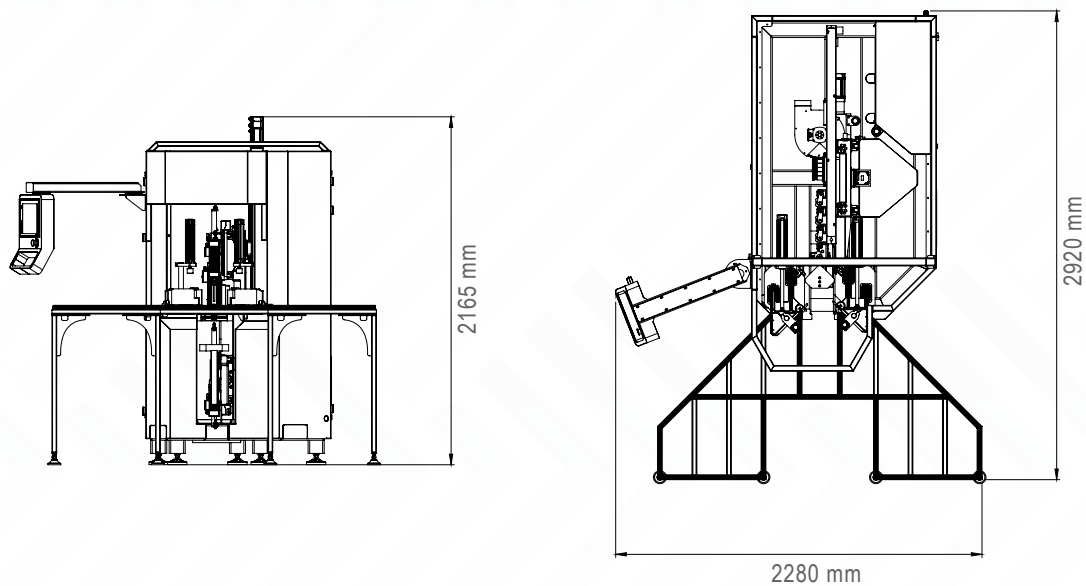

ORBIT - V, the Automatic PVC corner and surface cleaning machine, is developed for cleaning the burrs formed on the plastic profiles after the process of welding. Cleans the lower, upper, inner and outer surfaces of profiles by means of two independent cleaning units. 11 automatic profile cleaning blades provide the users with ease and time saving in burr cleaning process with its 1000 pcs. profile memory capacity and operator adjustable axial speeds.



# ORBIT - V

Automatic PVC Corner and Surface Cleaning Machine (4 Surfaces)



## CLEANING UNIT FRAME DIMENSIONS

Min. Frame Dimensions	350 mm x 400 mm
-----------------------	-----------------

## CLEANING UNIT PROFILE DIMENSIONS

Min. profile height	25 mm
Max. profile height	200 mm
Min. profile width	30 mm
Max. profile width	150 mm

## ELECTRICAL

Maximum power	10 kW
Voltage	400V 3P, N, PE AC
Frequency	50 Hz

## AIR

Pressure	6-8 Bar
----------	---------

## CUTTING UNITS

Saw blade diameter	300 mm
Saw blade motor power	1.1 kW
Saw blade motor	6000 r.p.m.
Saw blade thickness	3.2 mm
Milling cutter motor power (x2)	0,75 kW
Milling cutter motor r.p.m.	12.000 r.p.m.
Milling cutter diameter	8 mm
Milling cutter length	120 mm
Profile external cleaning saw	•
Cleaning blades	•
Millers	•

## PROCESSABLE UNITS

With sawblade (External surface)	1
With 3 upper and 3 lower blades (inner profile with upper and lower surface)	3
With 1 upper and 1 lower miller (cord housing and surface cleaning)	2

## OPERATIONAL AREA

Profil support unit	•
---------------------	---

- Standard    ○ Optional